

VEP K4-PPH

Electrically actuated butterfly valves



INSTRUCTIONS MANUAL

BAMO MESURES

22, Rue de la Voie des Bans - Z.I. de la Gare - 95100 ARGENTEUIL

Tél : (+33) 01 30 25 83 20 - Web : www.bamo.fr

Fax : (+33) 01 34 10 16 05 - E-mail : info@bamo.fr

**Electrically actuated
butterfly valves
VEP SK4-PPH**

02-01-2012

914 M1 06 B

PLAS

914-06/1

DESCRIPTION

Electric actuators are designed for controlling quarter turn plastic valves. For any other purpose, please report to us before start up; we may not be responsible of troubles due to other applications.

1. Fitting on the pipe line

1.1. Precautions

Before fitting the valve, it is necessary to verify the chemical compatibility between all the elements (*fluid vs. body, seals, seating joints*).

1.2. Assembly

Respect common precautions for the assembly of all elements together.
All parts should correspond in dimensions, pressure & temperature limits.

2. Electric motor connections

2.1. Precautions

- Fitting, connections, initial start-up and maintenance operations must be done by trained technicians.
All European and local rules for electric devices and systems must be respected.
- Follow the recommendations step by step as per following texts, otherwise a correct operation is not warranted.
- Check if the power supply input corresponds to the main power available on site (tag on the electric actuator)
- Do not fit the actuator head down.
- Do not fit the actuator at less than 30 cm from electromagnetic disturbance source.
- Do not wire several actuators on one reversing switch without lines separation
- **Shut off the main power supply before any operation such as:**
 - Opening the cover
 - Unlocking the clutch
 - Manual operating for emergency or maintenance
- The engine was tested on bench before shipment.
Limit switches are adjusted for a rotation of 90° (you may not have to modify this).
- Verify before mounting, the free rotation in place of manual handle (emergency manual override).
- The complete electric actuator is protection class IP65 and no need a specific maintenance.
- **An electric protection must be install (circuit-breaker, etc.) according to the engine power.**

2.2. Wiring and connecting automatism and power circuits

- Connection to earth (ground) is an obligation over 42 V voltage (today standards).

ND65 to ND100

- 3 Wires+Ground
DIN436560 connector

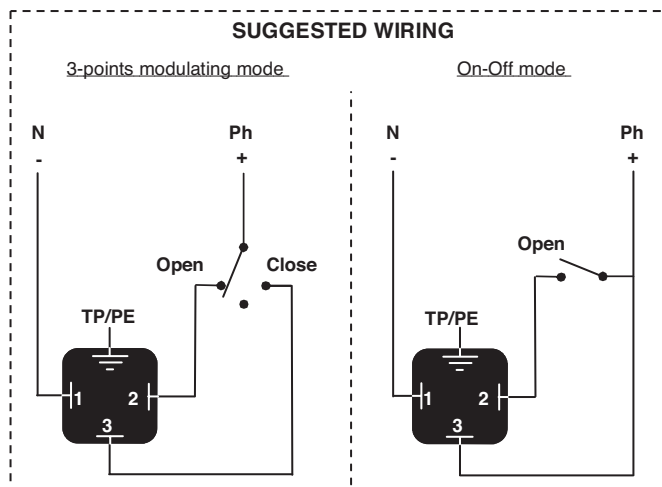

ND150 to ND200

- Connect to the earth through the exterior bolt M5 located under the cable gland.
(It is also possible to connect the actuator to earth inside the actuator through the bolt M3 next to the terminal strip)
- Unscrew the left cable gland and insert the cable.
- Connect the wires to the terminal strip in accordance with the required control mode.

3-points modulating mode

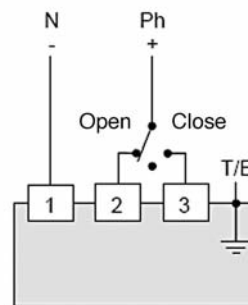

On-Off mode (pre-set to close)

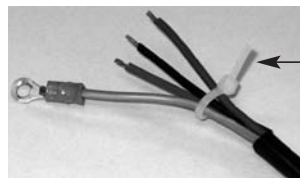
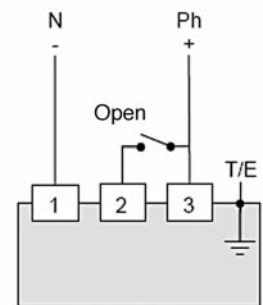

Put a lacing cord around the wires and re-tighten the cable gland.

Alternative current:

- Connect the earth (yellow/green wire) to TP/PE
- Connect Neutral in 1
- Connect opening signal wire to 2
- Connect closing signal wire to 3

Direct current:

- Connect 1 and 2 to the relay (or double reversing switch) necessary for a good direct current working.
- Make a shunt between 2 and 3

The earth connection is not necessary in low voltage.

Switch the connection if open close functions are not good.

2.3. Limit switches (See §5. Wiring diagram)

2 limit switches box are include in standard and they are set for a 90° rotation.

DN65 to ND100:

- Remove the manual emergency override or visual position indicator
- Remove the cover by unscrew the 4 screw
- Loosen the ISO M20 gland to reeve the wire
(ISO M20 gland is useful for 5.5 to 12 mm cable)

Now with the cover remove and the ISO M20 gland loosen you can plug the wires like this:

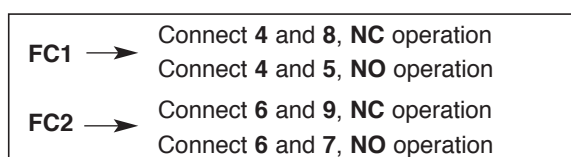

- For re-assembling the actuator make this operation in the reverse order

ND150 to ND200

Our actuators are equipped with two simple limit switch contacts normally set in their open position (NO). As per factory setting, the white cam is used to detect the open position (FC1) and the black cam is used to detect the closed position (FC2). This feedback system accepts voltages between 24 V and 240 V AC/DC.

- Unscrew the right cable gland and insert the cable.
- Remove 25mm of the cable sheath and strip each wire by 8mm.
- Connect the wires to the terminal strip in accordance with the diagram beside.
- Tighten the cable gland.

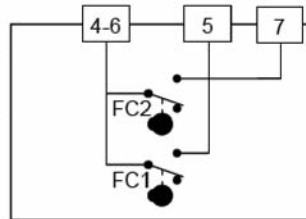

3. Emergency manual override

The priority functioning mode of this actuator is electric. Be sure that the power supply is switched off before using the manual override.

ND65 to ND100

- Turn the knob to position **MAN** (counter-clockwise) and hold it in position.
- Turn the outgoing drive shaft of the actuator with the help of an adjusting spanner.
- In order to re-engage the reduction, release the knob (spring return).

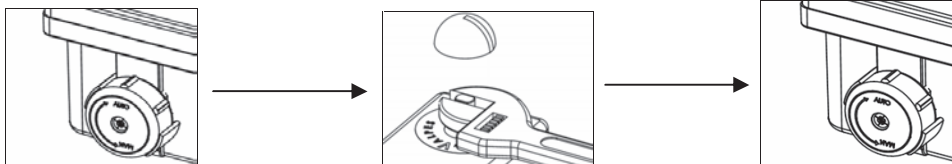

ND150 to ND200

Hand wheel emergency manual override

- No declutching is required
- The hand wheel has simply to be turned

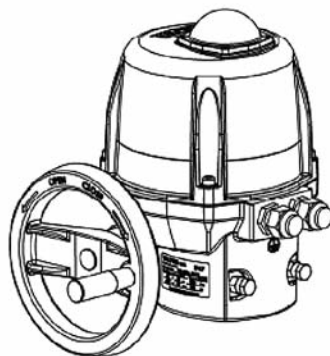

4. Technical data

ND65 to ND100

IP Protection:	IP65 (dusttight, water spraying "flow < 12.5l/min")
Corrosion resistance (<i>outdoor and indoor use</i>):	Plastic: PA6.6, ABS, raw material: 304L Stainless or steel + An treatment
Temperature:	-10°C to +55°C
Hygrometry :	< 81% to 31°C (88°F) with lineary decrease down to 50% at 40°C (according EN61010-1)
Pollution degree:	Class 2
Altitude:	0 to 2000m
Operating time:	around 10s
Rotation angle:	90°
Manual override:	Out axle
Voltage:	24V AC/DC 90V to 240V AC (90V to 350V DC)
Frequency:	50/60Hz
Power:	15W or 45W
Overvoltage category:	Category II
Torque limiter:	Electric
Duty rating:	30%
Limit switches maximal voltage:	4V to 250V AC/DC
Limit switches maximal current:	10mA to 5A max
Electrical wiring:	1 ISO M20 gland, 1 DIN43650 3P+T connector



**Follow the voltage tag
on the actuator**

ND150 to ND200

IP Protection:	IP67
Corrosion resistance (<i>outdoor and indoor use</i>):	Housing: Aluminium + EPOXY paint, Cover PA 6.6 V0, Drive: Steel + Zn Treatment, Axles and screws: Stainless steel
Temperature:	-20°C to +55°C
Hygrometry :	< 81% to 31°C (88°F) with lineary decrease down to 50% at 40°C (according EN61010-1)
Pollution degree:	Class 2
Altitude:	0 to 2000m
Operating time:	30s to 60s
Rotation angle:	90°
Manual override:	Hand wheel
Voltage:	24V AC/DC 90V to 240V AC (90V to 350V DC)
Frequency:	50/60Hz
Power:	45W
Overvoltage category:	Category II
Insulation motor class:	Class B
Torque limiter:	Electric
Duty rating:	50%
Limit switches maximal voltage:	250V AC/DC
Limit switches maximal current:	5A max
Electrical wiring:	2 ISO M20 gland
Regulated heating resistor power:	10W
Inrush current:	35A



**Follow the voltage tag
on the actuator**

4.1. Exploded view ND65 to ND100

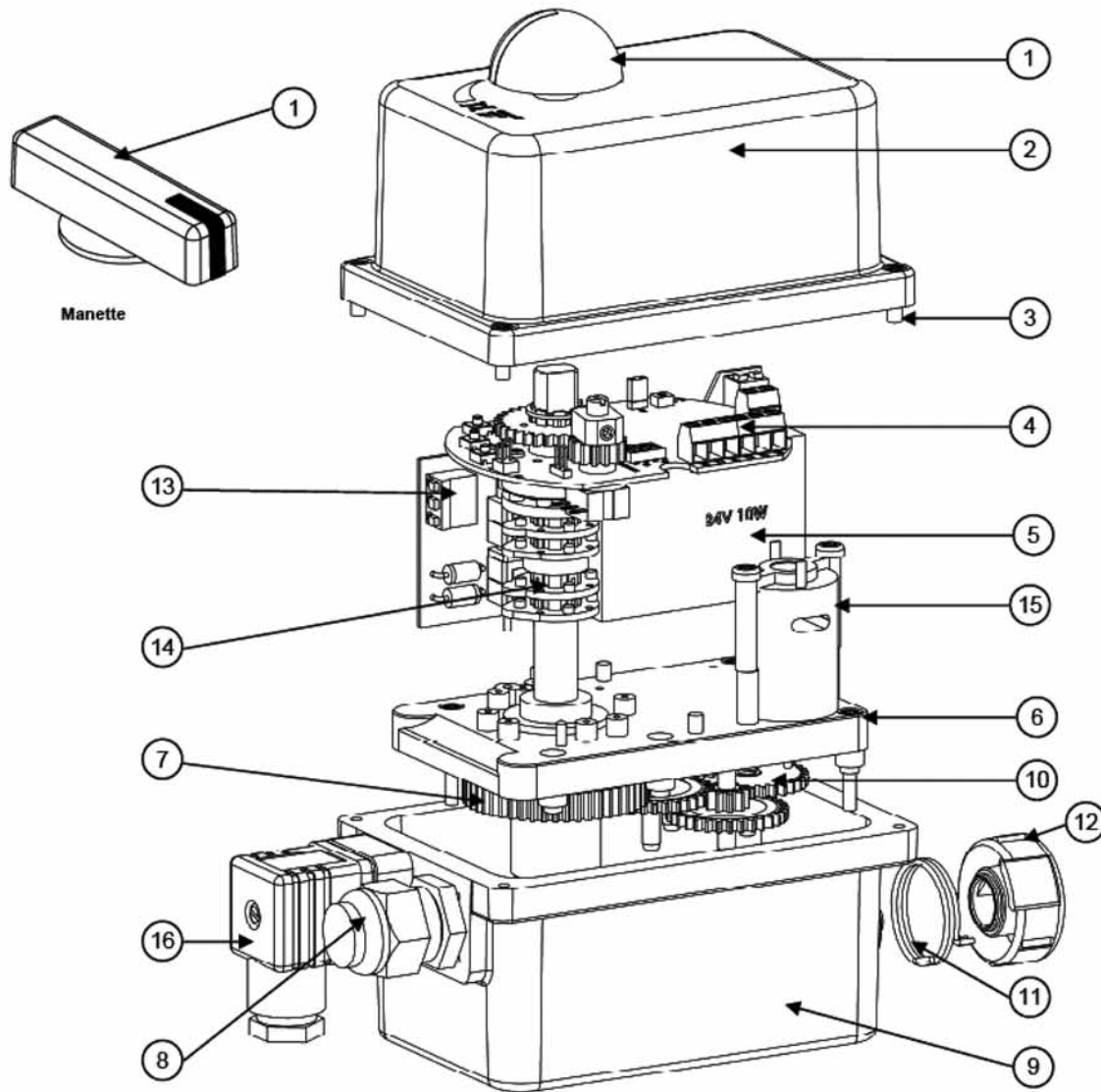

Rep.	Désignation	Designation	Bezeichnung
1	Indicateur visuel de position	Visual position indicator	Stellungsanzeige
2	Capot ABS	ABS cover	ABS Haube
3	Vis inox	Stainless steel screws	Edelstahl Schrauben
4	Bornier signal entrée / sortie	Input / output terminal trip	Anschlussklemmen des Signalgebers / Rückmeldung
5	Carte d'alimentation	Power supply card	Stromversorgung Karte
6	Plaque réducteur	Gear box plate	Getriebeplatte
7	Entraîneur	Shaft + sleeve	Antriebswelle
8	Presse-étoupe ISO M20	ISO M20 gland	PG Schrauben ISO M20
9	Carter Nylon	Nylon housing	Gehäuse
10	Engrenages	Gears	Getriebe
11	Ressort	Spring	Feder
12	Bouton de débrayage	Clutch knob	Schaltknopf
13	Bornier fin de course auxiliaire	Aux. Limit switch terminal trip	Zusätzlicher Endschalter
14	Cames	Cams	Nocken
15	Moteur	Motor	Motor
16	Connecteurs 3P+T (DIN436560)	Connectors 3P+T (DIN436560)	Gerätesteckdosen 3P+T (DIN436560)

4.2. Exploded view ND150 to ND200

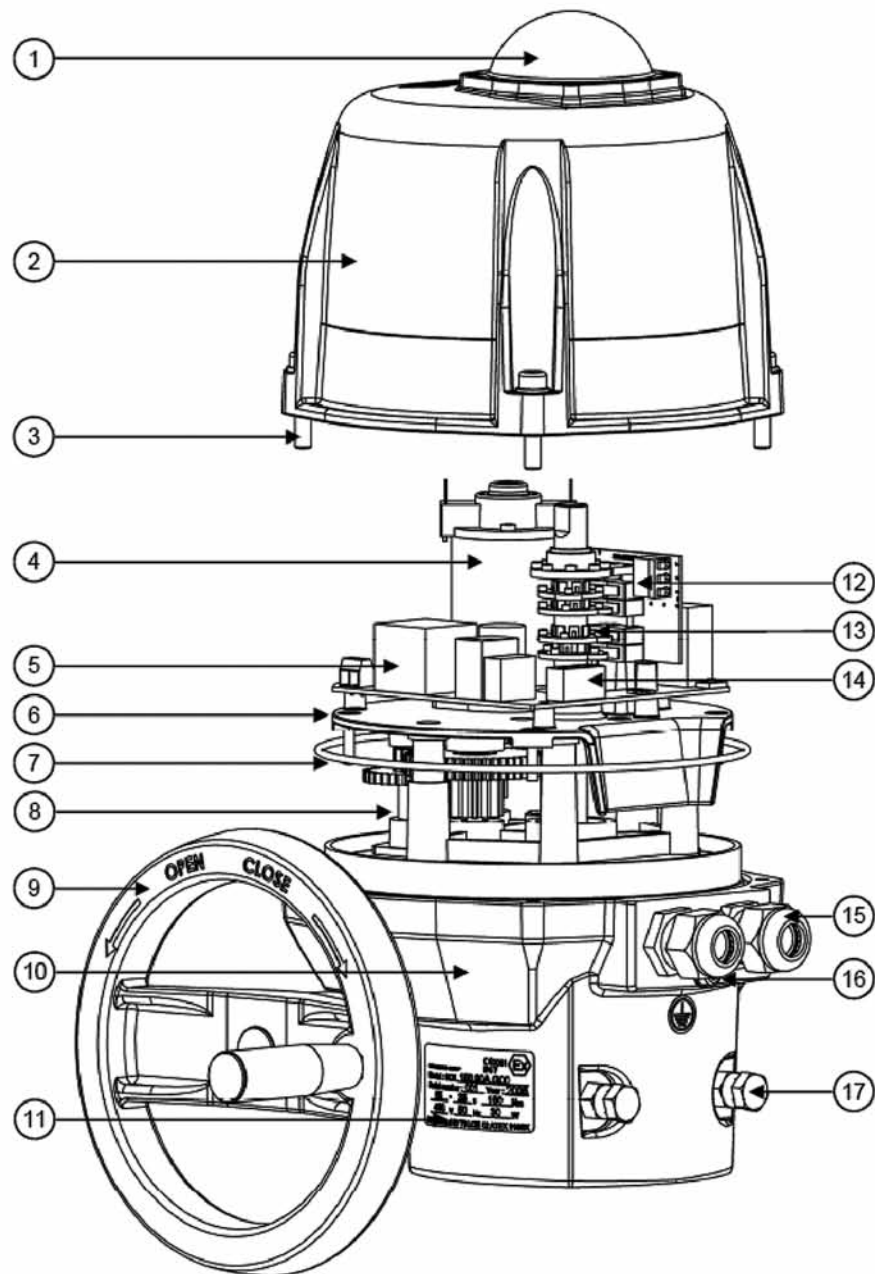

Rep.	Désignation	Designation	Bezeichnung
1	Indicateur visuel de position	Visual position indicator	Stellungsanzeige
2	Capot	Cover	Haube
3	Vis inox	Stainless steel screws	Edelstahl Schrauben
4	Moteur	Motor	Motor
5	Carte alimentation et commande	Pilot and power supply card	Steuerung und Stromversorgung Karte
6	Plaque réducteur	Gear box plate	Getriebeplatte
7	Joint torique	O ring	O Ringdichtung
8	Réducteur	Gear box	Getriebe
9	Volant	Hand wheel	Handrad
10	Carter	Housing	Gehäuse
11	Étiquette d'identification	Identification label	Identifizierungsetikett
12	Bornier fin de course auxiliaire	Auxiliary limit switch terminal	Zusätzlicher Endschalter Verbindung
13	Cames	Cams	Nocken
14	Bornier alimentation et commande	Pilot and power supply terminal	Steuerung und Stromversorgung Verbindung
15	Presse-étoupe ISO M20	ISO M20 gland	PG Schrauben ISO M20
16	Vis de terre	Earth screw	Erde Schraube
17	Butées mécaniques	Mechanical end stops	Mechanische Endhalterung

5. Electric wiring

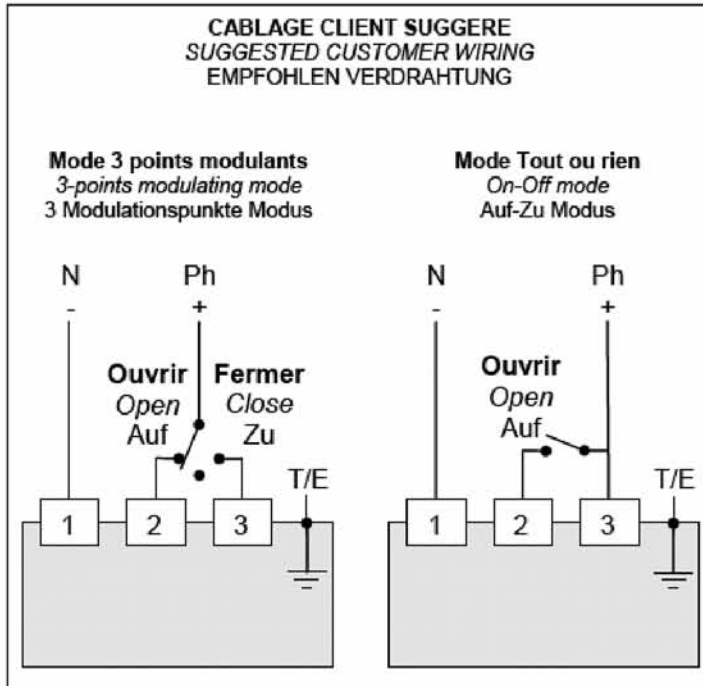

REP	DESIGNATION BESCHREIBUNG
FC0	Fin de course ouverture <i>Open limit switch</i> Endschalter AUF
FCF	Fin de course fermeture <i>Close limit switch</i> Endschalter ZU
FC1	Fin de course auxiliaire 1 <i>Auxiliary limit switch 1</i> Zusätzlicher Endschalter 1
FC2	Fin de course auxiliaire 2 <i>Auxiliary limit switch 2</i> Zusätzlicher Endschalter 2



TENSION INDIQUEE SUR L'ACTIONNEUR : 24V AC/DC ou 100-240V AC (120-350V DC)
INDICATED VOLTAGE ON ACTUATOR : 24V AC/DC or 100-240V AC (120-350V DC)
SPANNUNG, DIE AUF ANTRIEBE GEZEIGT IST : 24V AC/DC ODER 100-240V AC (120-350V DC)

ALIMENTATION ET COMMANDE
POWER SUPPLY AND COMMAND
SPANNUNGSVERSORGUNG UND STEUERUNG

RECOPIE
FEEDBACK
RÜCKMELDUNG

