

**Code : 730 998**  
**Contact bistable NO**  
**Réf : Z42**

Exemple : Câblage avec le relais ES 2001

**Artikel-Nr.: 730 998**  
**Bistabiler Schließer**  
**Bezeichnung: Z42**

Beispiel: Elektrischer Anschluss an das ES2001-Relais

**ATTENTION**  
 Floteur magnétique indispensable  
 Montage du presse étoupe vers le bas impératif  
 Respecter le pouvoir de coupure

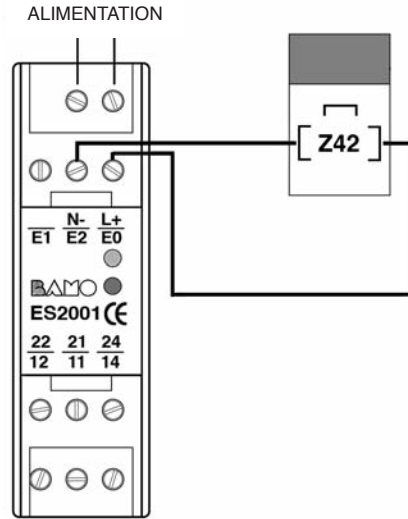

730 MX 07 B -- 11-09-2012

www.bamo.fr

**ACHTUNG**  
 magnetischer Schwebekörper erforderlich  
 Montage der Kabelverschraubung  
 nach unten ist zwingend erforderlich  
 Schaltleistung beachten

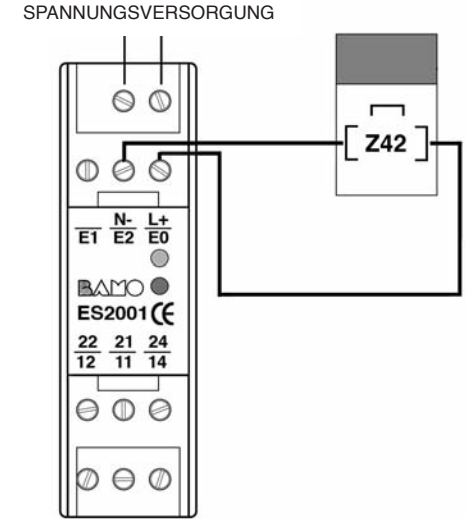

www.bamo.de

**CARACTERISTIQUES TECHNIQUES**

Pouvoir de coupure : Maxi 12 VA / 230 V AC / 0,5 A  
 Fonction : Par absence de débit  
 (Bistable NO, Code 730 998)  
 Protection : IP 65 - Bornier débrochable  
 T° ambiante : 0...+55 °C

**Technische Daten**

Schaltleistung: Max. 12VA / 230V AC / 0,5A  
 Schaltelement: Schließerfunktion (Standard),  
 (Art.-Nr.: 730 998)  
 Schutzart: IP65 - steckbare Anschlussleiste  
 Betriebstemperatur: 0...+55°C

**Code number: 730 998**  
**Alarm switch NO**  
**Ref: Z42**

Example: Wiring with amplifier relay ES 2001

**Código: 730 998**  
**Contacto eléctrico NA**  
**Ref: Z42**

Ejemplo: Cableado con relé ES 2001

**CAUTION**  
 A magnetic float must be used  
 The cable outlet must be downward  
 Respect the switching power

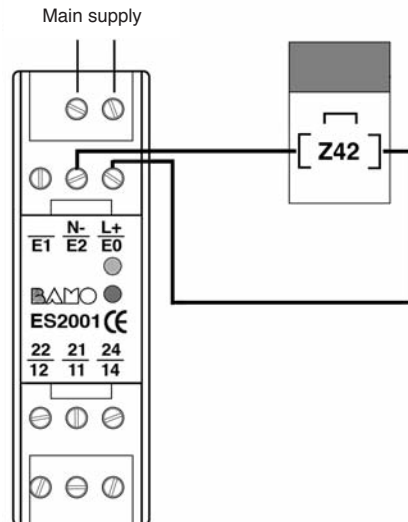

www.bamo.eu

**Cuidado**  
 El caudalímetro debe ser equipado con flotador magnético  
 Montaje con el prensaestopas hacia abajo  
 Respetar el poder de conmutación

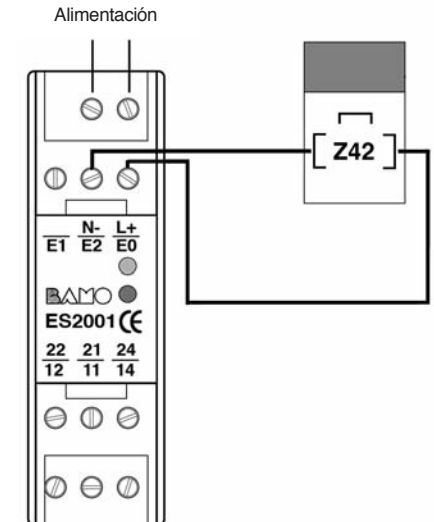

www.bamo.es

**TECHNICAL FEATURES**

Switching power: Maxi 12 VA / 230 V AC / 0,5 A  
 Status: NO with flow-less  
 (Code number 730 998)  
 Protection: IP65 - Pluggable terminal strip  
 Temperature limits: Room 0...55°C, Fluid 0...55°C

**CARACTERÍSTICAS TÉCNICAS**

Capacidad de ruptura: Máximo 12 VA / 230 V AC / 0,5 A  
 Estado: Por ausencia de caudal NA, Bi-estable  
 (Código 730998)  
 Protección: IP 65 - Terminal  
 Limite temperatura: 0 ... +55°C para ambiente

