

RDP 906

PRESSURE REDUCING VALVES



INSTRUCTIONS MANUAL

BAMO MESURES

22, Rue de la Voie des Bans - Z.I. de la Gare - 95100 ARGENTEUIL

Tél : (+33) 01 30 25 83 20 - Web : www.bamo.fr

Fax : (+33) 01 34 10 16 05 - E-mail : info@bamo.fr

**PRESSURE REDUCING
VALVES**

RDP 906

02-01-2012

906 M1 02 C

PLAS

906-02/1

1. MANUFACTURER DECLARATION

BAMO Mesures SAS, declares that the pressure reducing valves **RDP 906**, due to their non ability to be used with dangerous fluids flammables and gaseous because of their Nominal Diameters and Pressure Class, are not concerned by the Directive **EC 97/23 CE** relative to pressure apparatuses

2. APPLICATION

A pressure reducing valve RDP 906 maintains constant the pressure downstream, at the adjusted value (lower than the upstream pressure). An EPDM diaphragm, PTFE coated, separates the mechanical parts body and the channel. All wetted parts are in plastics. Without metallic parts exposed to the atmosphere it allows a location of the valve in aggressive, corroding ambient. The seat seal is in EPDM or FPM according to the model and connections.

The downstream pressure is adjustable from 1 to 9 bar with an upstream pressure up to 10 bar.

These equipment protection devices may be fitted in any position, in line, or on by-pass according to the application.

3. TECHNICAL FEATURES

Body:	PPG (Glass fibre reinforced Polypropylene)
Diaphragm:	EPDM, PTFE coated
Seat seal and O-rings:	or EPDM or FPM
Adjustable range:	1...9 bar
Pressure:	Class PN 10 (at 20°C) ; [bar]
Inlet / outlet size:	DN 10 to DN 25
Connections:	DIN 8068 threaded PVC union to glue on site PPH union to weld on site
Temperature limits	PPH: 10 to 70°C ; PVC: 10 to 50°C

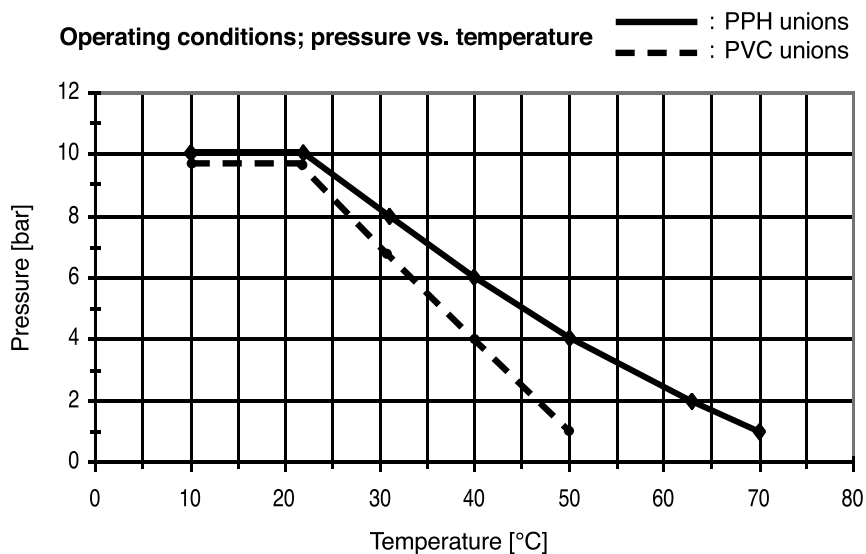

4. MOUNTING

- Connect the valve to a pipe free from any mechanical stress and, when it is possible, with dismantable connections.
- Respect the flow direction shown by the arrow on the body.
- Install a filter to prevent clogging when the fluid contains particles.
- Mount the valve in any position.
- These valves can be fixed on a support through the threads below the body.

5. ADJUSTMENT

a) Start up

Proceed for the first set up with a **downstream and upstream lines closed** (no flow) and without pressure.

- Use a pressure gauge fitted on the downstream line to read the set up pressure.
- Take of the protective cap, unscrew the lock nut, and unscrew the adjustment knob as much as possible to obtain the lowest set up pressure configuration.
- Open the lines and proceed to adjustment as following.

The diaphragm or the piston will be damage by an excessive tightening of the adjustment knob.

b) Adjustment

- Screw on the adjustment knob to increase the set up pressure.
- Unscrew the adjustment knob to decrease the set up pressure.

Once adjusted the set up pressure, block the adjustment knob with the blocking nut.

6. CHEMICAL COMPATIBILITY

First of all, verify the chemical compatibility of the valve materials (body, seat seal and o-rings, connections) with the fluid in use.

7. CODE NUMBERS

RDP 906 with PVC unions to be glued on site		
ND	Sealing EPDM	Sealing FPM
ND 10	906 001	906 011
ND 15	906 002	906 012
ND 20	906 003	906 013
ND 25	906 004	906 014

RDP 906 with PP unions to be welded on site		
ND	Sealing EPDM	Sealing FPM
ND 15	906 102	906 112
ND 20	906 103	906 113
ND 25	906 104	906 114

Any other material or model: please contact us

8. DIMENSIONS

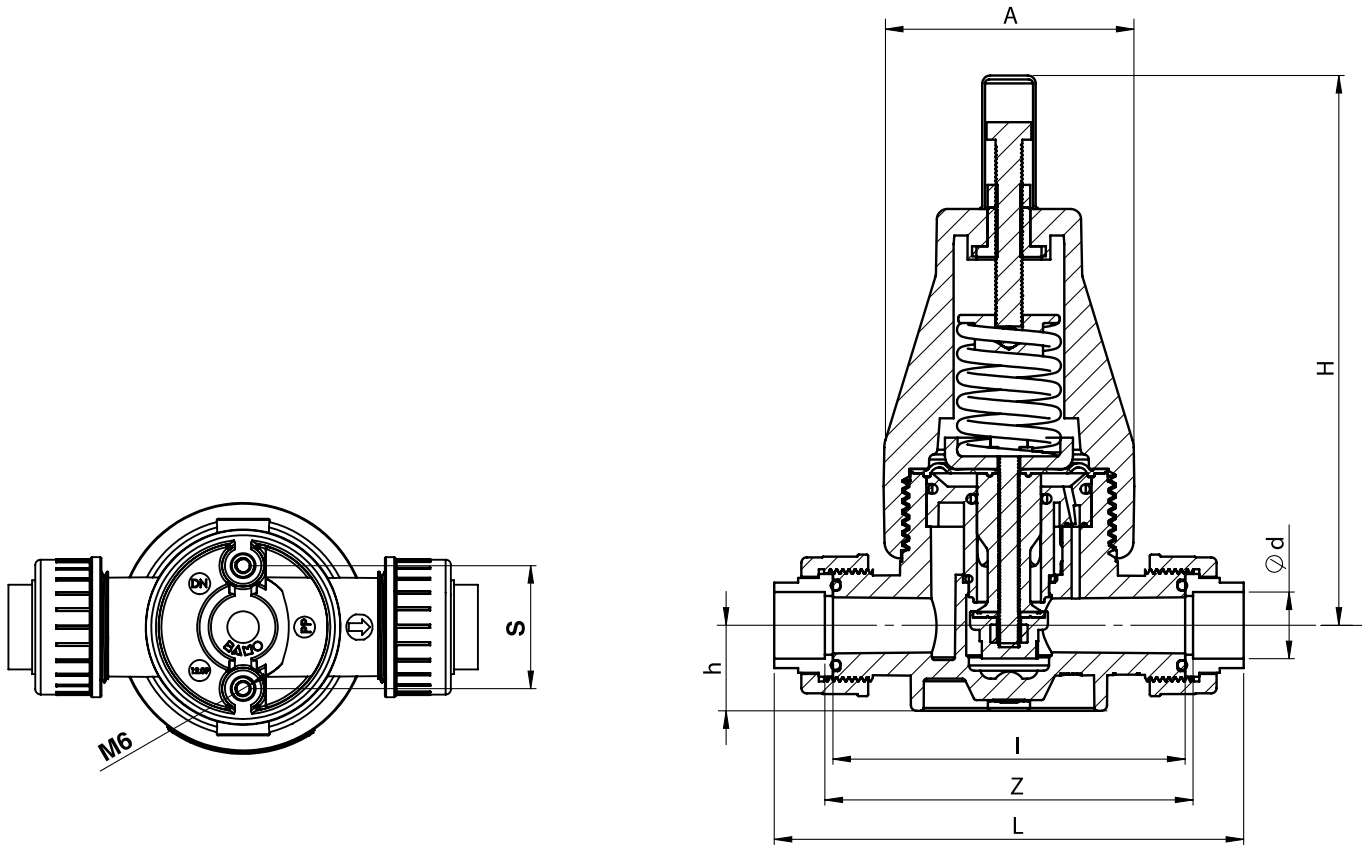

ND	d (mm)	A [mm]	H [mm]	h [mm]	I [mm]	S [mm]	Z [mm]		L [mm]		Mass [Kg]
							PVC	PPH	PVC	PPH	
ND 10	16	80	186	24	112	40	118	-	147	-	0,52
ND 15	20	80	186	24	112	40	118	118	152	151	0,53
ND 20	25	94	210	32	132	46.5	138	138	176	175	0,93
ND 25	32	94	210	32	132	46.5	138	138	182	179	0,96

FLOW RATE LIMITS

ND	Flow rate [l/h] *
ND 10	900
ND 15	2000
ND 20	3500
ND 25	5500

* Measured maxima according to a fluid speed of 3 m/s approx.
The speed of 3 m/s may be considered as a maximum.
Above 3 m/s the plastic devices will be damaged.

For water at 20°C