

BAMOFLU 100

FLOW SENSOR



INSTRUCTION MANUAL

BAMO MESURES

22, Rue de la Voie des Bans - Z.I. de la Gare - 95100 ARGENTEUIL

Tél : (+33) 01 30 25 83 20 - Web : www.bamo.fr

Fax : (+33) 01 34 10 16 05 - E-mail : info@bamo.fr

Flow sensor
BAMOFLU 100

27-05-2014

780 M1 01 E

MES

780-01/1

1 PRINCIPLE

The flowing fluid maintains in rotation the five blades rotor. Each blade has a built-in magnet, not in contact with the fluid. The magnetic field variation induces a pulsating signal with its frequency proportional to the fluid speed. Our sensor emits a signal frequency about 38 to 45 Hz/m/s (depending of process parameters).

This measurement method assures an excellent response with flow velocity (the minimal flow velocity is 0.8 m/s). The flow could be loaded up to 2% of non-magnetic particles. The fluid viscosity value should be between 0.5 to 20 cSt at process temperature, otherwise a calibration on site is necessary.

2 MOUNTING

Flow sensor and installation fittings are available for pipes from DN 15 to DN 600, in stainless steel, PVC, PPH and PVDF. Te fittings are available from DN 15 to DN 50, and collars from DN 40 to DN100. Weld on adaptors in stainless steel are convenient from DN 50 to DN 600; same figures for glued or welding adaptors proposed in PVC, PPH and PVDF. The sensor works in any position and on both flow directions. It is necessary to respect pipe straight lengths upstream and downstream in order to avoid turbulences..

3 TECHNICAL FEATURES

Output frequency:	38 to 45 Hz (depends of process)
	Square signal 5 to 24 V DC
Power supply:	24 V DC - 30 mA
	Sensor protection against reversed polarity
Speed flow range:	0.8 to 10 m/s
Accuracy:	±1% full scale
Repeatability:	±0.5 %
Linearity:	±1 %
Maximal pressure:	10 bar at 20°C / PPH, PVDF
	25 bar / Stainless steel
Maximal temperature:	85°C / PPH – 100°C PVDF, Stainless steel 316 L
Body sensor:	PPH – PVDF – Stainless steel 316 L
Rotor:	5 blades in E-CTFE (Halar)
Rotor bearings:	Ceramic (AL2O3)
Sealing:	O-ring FPM on standard – EPDM on request
Wiring:	With DIN 43650 plug - IP65

4 WIRING

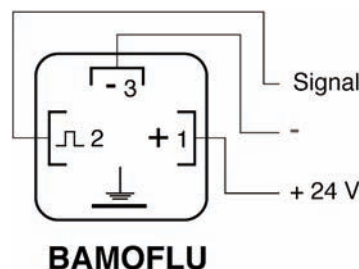

5 INSTALLATION

To obtain a reliable measurement, it is necessary to respect following conditions:

- The pipe has to be always full of fluid
- Never a gaseous phase exists
- Flow velocity should be between 0.8 and 10 m/s

6 STRAIGHT LENGTHS REQUIRED

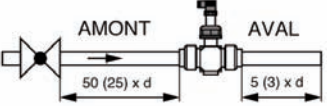
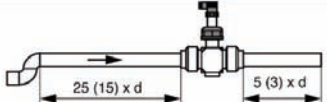
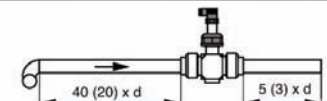
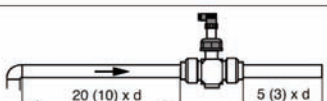
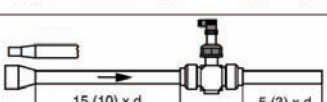
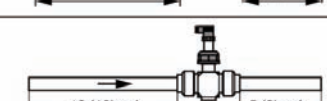
Regulation valve	
2 elbows, angle 90° on the same orientation surface	
2 elbows, angle 90° different orientation surfaces	
1 elbow on a Te	
Enlargement or reduction coupling	
Straight pipe	

According to standard NF X 10 – 102 (DIN 1952)

7 MOUNTING POSITION

It is important to respect straight lengths upstream and downstream to avoid turbulences.

The BAMOFLU can be mounted in any position. However, it is required to install the sensor with a light angle from vertical axis: because of air bubbles or particle deposits.

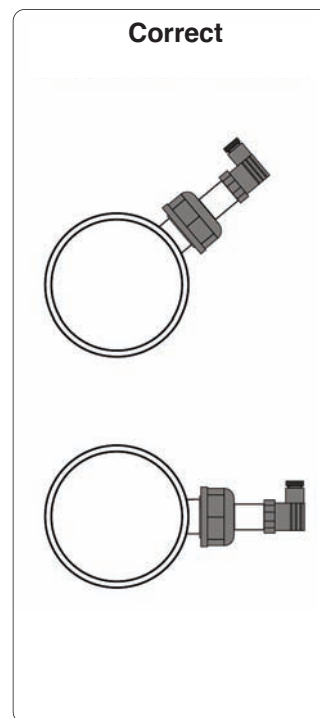
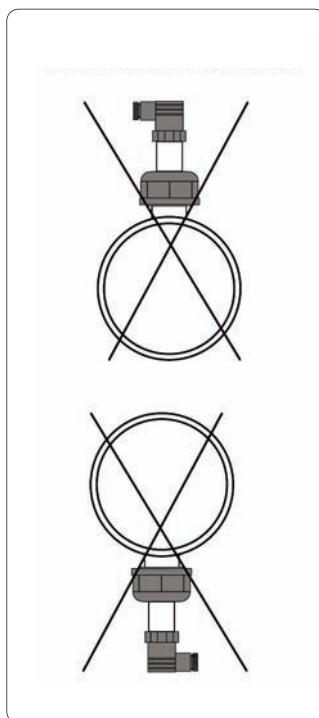

8 Te - FITTINGS

PVC, PPH, PVDF or stainless steel 316L Tees are available for pipes from DN 15 to DN 50. Complete with 2 half socket unions and FPM O Rings. Flange connections or socket ends for solvent welding /gluing are on request.

For nominal diameters DN 15 to DN 300, we can supply 250 mm long coupling sleeve with flanges (all materials) on request.

Flow pipe: DN 15 (Ø 20 mm) to DN 50 (Ø 63 mm)
 Maximal pressure: 10 bar at 20°C
 Maximal temperature: 100°C

Connections: or fitting material limits
 Female solvent sockets - PVC
 Female welding sockets - PPH - PVDF

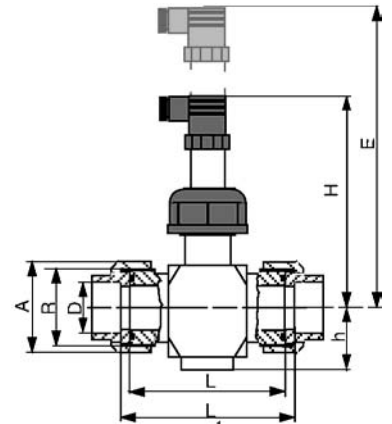

DN	D	R	A	L	L1	h	H	E	Code number		
									PVC	PPH	PVDF
mm											
15	20	1"	40.5	120	124	37	168	243	780 205	780 240	780 260
20	25	1" 1/4	50	120	126	35	170	245	780 207	780 242	780 262
25	32	1" 1/2	57.5	120	128	32	173	248	780 209	780 244	780 264
32	40	2"	71.5	120	128	48	177	252	780 211	780 246	780 266
40	50	2" 1/4	79	120	124	42	181	256	780 213	780 248	780 268
50	63	2" 3/4	98	120**	124**	49	180	255	780 215	780 250	780 270

** Size not valid if PVDF material

9 COLLARS

Only for mounting on plastic pipes (PVC, PE or PPH), we propose pipes collars in PPH with NBR O-ring (EPDM or FPM on request). Screws are in galvanized steel. Plastic pipes are considered as PN 10, if any other specification please consult us. The collars are supplied with the special fitting for BAMOFLU with a threaded socket. The complete assembly respects the mounting position 0.12 x Ø.

DN	Ø d	L	H*	E*	Ref.	Code
40	50	104	236	346	COL 50	780 901
50	63	116	240	350	COL 63	780 906
65	75	134	244	354	COL 75	780 911
80	90	152	249	359	COL 90	780 916
100	110	176	255	365	COL 110	780 921

Pipes: DN 40 (Ø 50 mm)
 to DN 100 (Ø 110 mm)
 Maximal pressure: 10 bar at 20°C
 Maximal temperature: 55°C

10 WELD-ON ADAPTORS BF 150

Available for pipes DN 50 as a minimum, in stainless steel 316L, PVC, PPH or PVDF. The adaptor allows sensor mounting on pipe.

For mounting with weld-on adaptors, it is important to respect the distances specified on the drawing, in accordance with the standard ISO 7145-1982.

Reference	Code	Designation
BF 150-I	780 200	Weld-on adaptor in Stainless steel
BF 150-PVC	780 201	Weld-on adaptor in PVC
BF 150-PPH	780 202	Weld-on adaptor in PPH
BF 150-PVDF	780 203	Weld-on adaptor in PVDF

