

BAMOBUL

AIR BUBBLING LEVEL TRANSMITTER



INSTRUCTIONS MANUAL

BAMO MESURES

22, Rue de la Voie des Bans - Z.I. de la Gare - 95100 ARGENTEUIL

Tél : (+33) 01 30 25 83 20 - Web : www.bamo.fr

Fax : (+33) 01 34 10 16 05 - E-mail : info@bamo.fr

Air bubbling level transmitter
BAMOBUL

28-05-2007

758 M1 01 C

DEB

758-01/1

1. TECHNICAL FEATURES

Level transmitter

| | |
|--------------------|---|
| Scales: | 0...30 / 0...50 / 0...100 / 0...300 / 0...500 mm WC (others on request) Please specify the desired scale when ordering |
| Temperature limits | 0...50°C |
| Accuracy: | ± 1% full scale |
| Response time: | <10 ms |

Air generation

| | |
|----------------------|--|
| Flow rate: | approximately 250 L/h (free outlet) |
| Maximal pressure: | 250 mbar (approximately 2000 mm WC) |
| Pump body: | ABS |
| Air flow adjustment: | from 0 to maximal flow, regulated for a constant flow rate |
| Power supply: | 230V – 50/60 Hz – 8 VA |

Transmitter

| | |
|--------------------|---|
| Adjustment: | 0 and full scale by potentiometer |
| Default detection: | tube breaking or choked outlet 1 Volt free change over contact output, switching power 230V / 5A |
| Output: | 4-20mA (power supply included) / max 600 ohm / limit 23 mA |
| Presentation: | wall mounting, IP55 |
| Dimensions: | 257 x 236 x 95 mm |

Bubbling air stem

| | |
|---------------------|--|
| Material: | Stainless steel 316L, PPh (other on request) |
| Process connection: | BSP 1/2" with counter nut |
| Height adjustment: | sliding connector with gland |
| Height: | According to each scale |
| Air tubing: | RILSAN tube 6 x 4 mm |

2. CAUTION

- The BAMOBUL must be installed on a stable, vibration free holder, with ambient T° between 0 and 50°C out of direct sun shining.
- Wiring, on screw terminal, must be done by a specialist.
- Any damage due to an error will cancel the warranty.
- Before to start it up, verify if wiring is correct and check the pneumatic connections between BAMOBUL and air bubbling stem.

3. DESCRIPTION

BAMOBUL is designed for Venturi channel water level measurement up to 500 mm.

This instrument is well known for its reliability and the accuracy of signal output even whit particles in the fluid or foam over the surface.

An air pump generator creates an adjustable pressure against the water column. This pressure difference from the atmospheric pressure is directly proportional to the water height.

The 4-20 mA is then useful for a calculator with a passive input.

4. DIMENSIONS

HOUSING

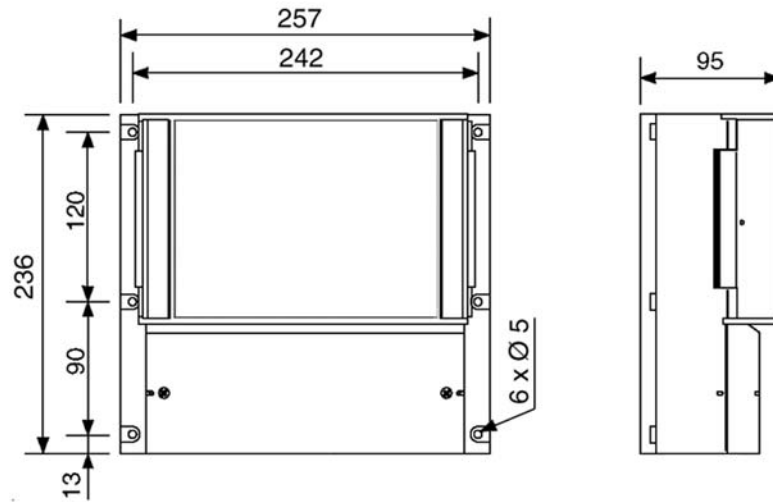

AIR BUBBLING STEM

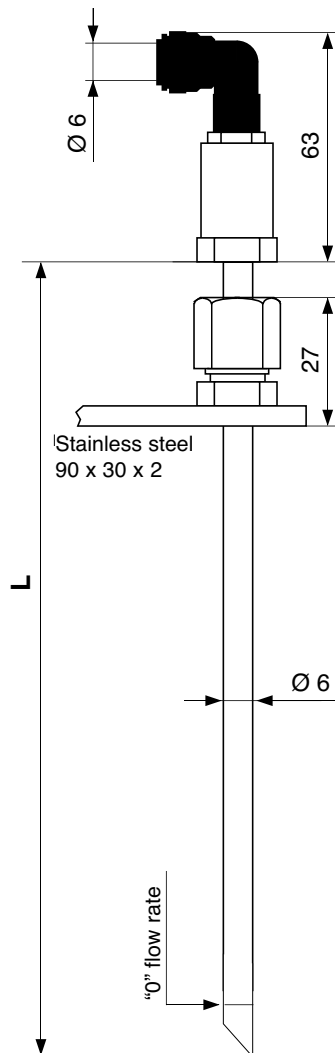

The BAMOBUL must be connected to the air bubbling stem immersed in the liquid.

5. BAMOBUL AND AIR BUBBLING STEM SETTING

The BAMOBUL must be set on wall support as indicated on drawing. The stand must be vibrations free and not exposed to direct sun shining, with a maximal temperature of 50°C.

The tubing and cables must not be tensed or bent.

With a Venturi channel, the air bubbling stem is inserted in the sided measurement well. A special care is necessary to avoid any vibration of the stem due to the flowing liquid.

The stem should always be immersed in the liquid.

When the flow rate is 0, the stem is immersed until the mark "0" reaches the liquid surface:

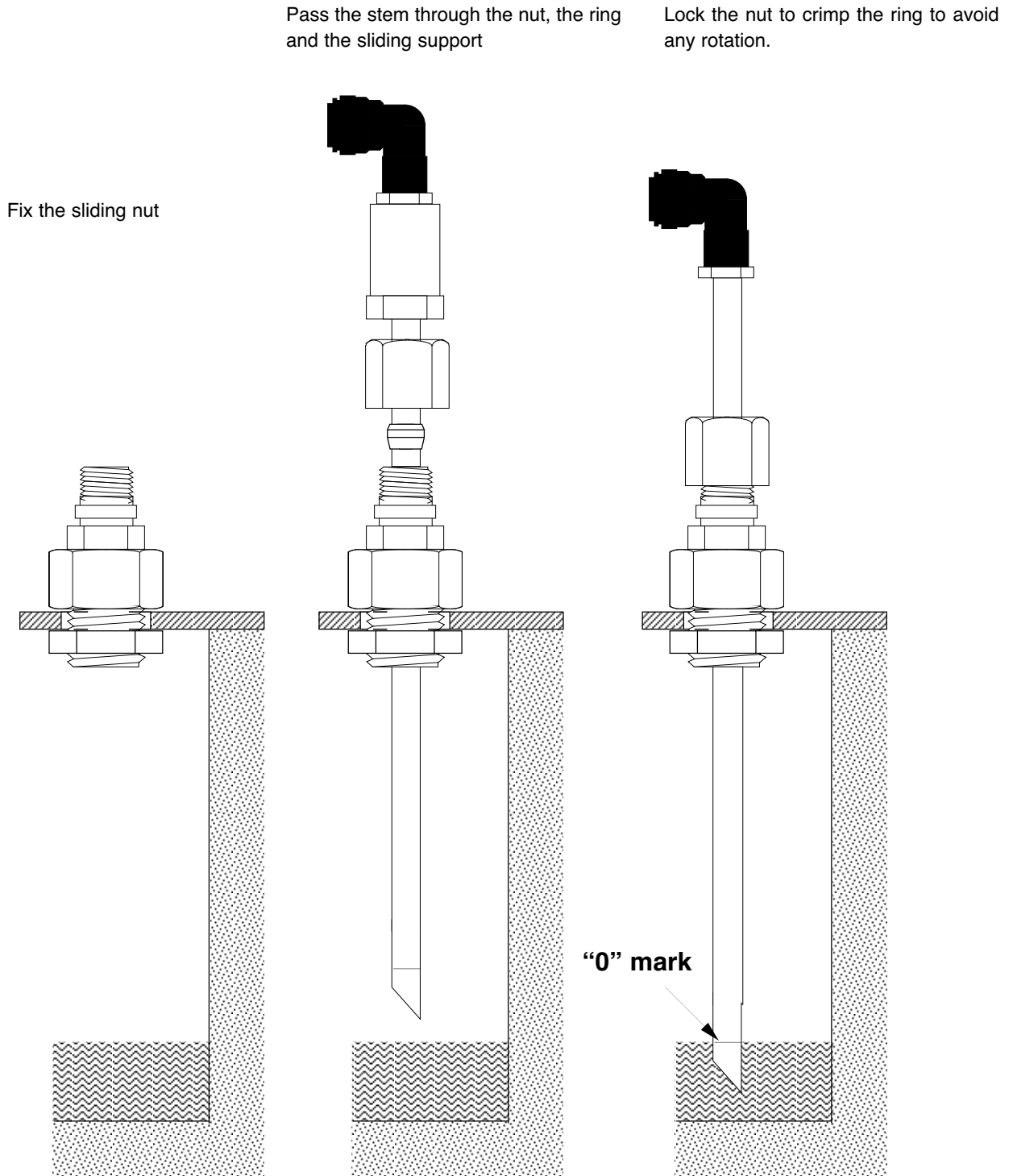

The height of level "0 flow rate" is always the same, repositioning after cleaning is then easy.

6. WIRING

By unscrewing the lower cover, you have access to the screw terminals.

6.1 Power supply

Standard power supply is 230 V – 50/60 Hz – consumption 7 VA.
This is specified on the electronic board, please check.

6.2 Analogical output

A dysfunction alarm relay is operated when the stem is choked (dirt, signal > 20 mA), for a lack of airflow (open air circuit, breaking tube, signal > 4 mA).
This relay is factory calibrated and cannot be modify by the user.

6.3 Relay output

Le BAMOBUL est équipé d'un seuil d'alarme pour la détection de bouchage ou de rupture du tuyau d'alimentation d'air de la canne de bullage. Lorsque l'image du niveau (en mA) passe en-dessous de 4 mA, l'appareil détecte une rupture du tuyau. De même, au-dessus de 20 mA, il y a une détection de tuyau bouché.
Ce seuil, branché en série avec une alarme ou un voyant lumineux, est très utile pour détecter les causes d'une panne et ainsi y remédier rapidement. Il est à préciser que cette sortie a été réglée en usine et n'est pas paramétrable par l'utilisateur.

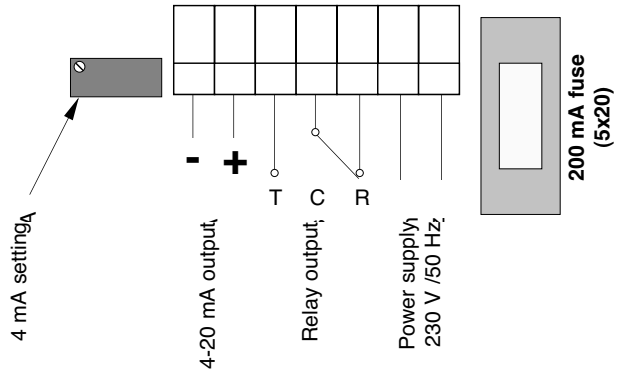

7. PNEUMATIC CONNECTION

Connection between the BAMOBUL and the air bubbling stem is a 6 x 4 mm RILSAN tube. Insert the tube in the BAMOBUL and the stem connectors. Take care not to pierce or bend the tube.

The tube should be installed to avoid elbows and tapping condensate.

On this outlet connection type, tube must be perfectly cut and with a straight length of several centimetres to keep a good air tightness.

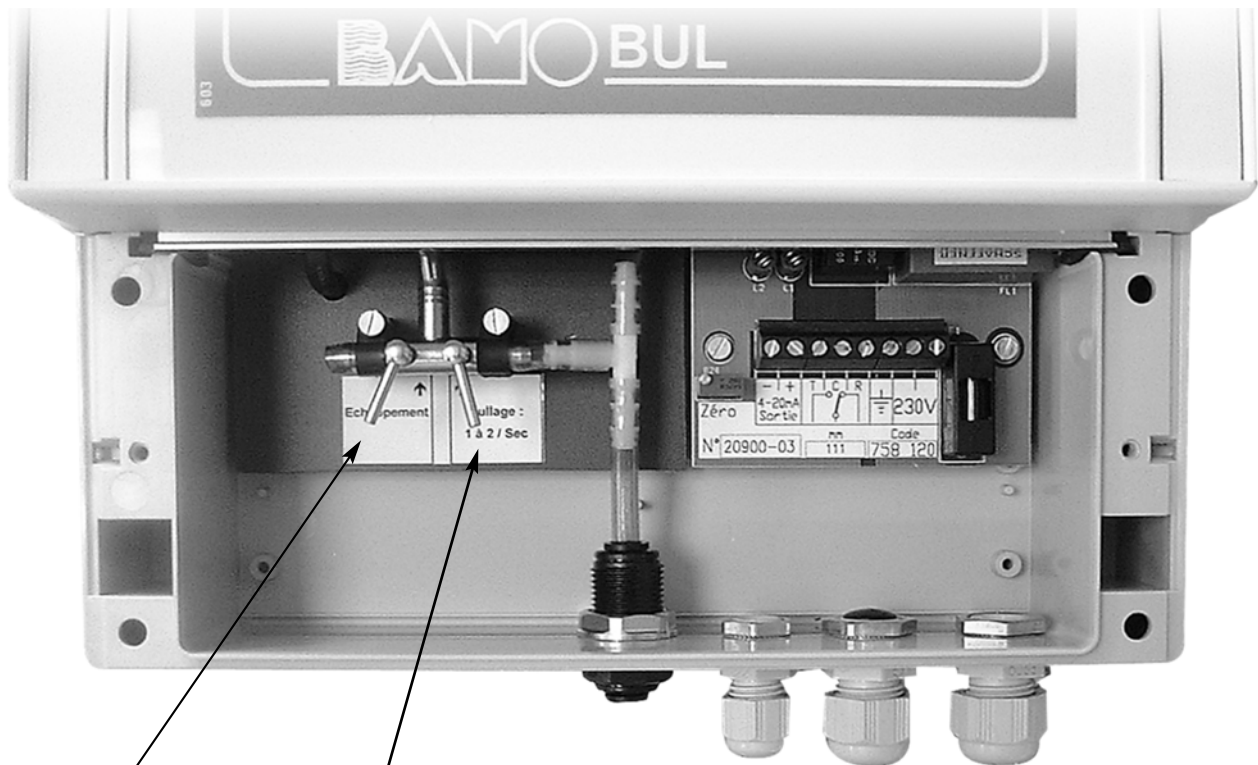

Air exhaust tuning

Bubbling frequency adjustent

8. CALIBRATIONS

This instrument is factory calibrated, however it is possible to modify it; proceed as follow.

8 - 1 Air flow adjustment

Removing the protection cover, you access to two needle valves on air circuit.

The first one is to adjust the bubbling flow rate, and the second one is to adjust compensation with exhausting air.

Adjust the exhausted flow until you get bubbles with the full scale. Then adjust the bubbles quantity with the bubbling flow rate valve.

The bubble frequency must be close to two bubbles per second.

This calibration can be done at the "0" point or at the full scale.

When the liquids are highly polluted with particles, it is possible to raise the airflow in order to avoid too frequent tapping and cleaning operation.

8 - 2 Analogical output adjustment

BAMOBUL is delivered calibrated depending of the Venturi in use (or Weir plate). It might be necessary to re-adjust the "0", so proceed as follow.

Connect a multi-metre to the mA; output: signal must be exactly 4 mA for 0 mm water height (no liquid flow). To modify it, use the 4mA adjustment potentiometer on left side of screw terminal. Check the 4 mA is really at 0 mm water height.

In any case do not touch the 20 mA potentiometer, which is calibrated in factory; this will totally unbalance your BAMOBUL and make non-reliable the measurements.

9. CLEANING

It is better to use the dysfunction relay to detect and clear air problems.

Air bubbling stem must be clean regularly to avoid measurement errors. You may determine the frequency necessary for cleaning the stem.