

TURBICUBE 1000

In-line turbidity transmitter
From 0.1 to 1000 FNU



INSTRUCTIONS MANUAL

BAMO MESURES

22, Rue de la Voie des Bans - Z.I. de la Gare - 95100 ARGENTEUIL

Tél : (+33) 01 30 25 83 20 - Web : www.bamo.fr

Fax : (+33) 01 34 10 16 05 - E-mail : info@bamo.fr

In-line turbidity transmitter
TURBICUBE 1000

12-03-2015

444 M1 02 E

MES

444-02/1

1 SAFETY PRECAUTIONS

- Only qualified person should operate, install and assure the maintenance.
- The device may only be connected to supply power, which complies with the specifications included in the technical data.
- The device must be disconnected from all sources of power during installation and maintenance work.
- The device may only be operated under the conditions specified in the operating instructions.

2 FUNCTIONS - DESCRIPTION

The turbidity-measuring device determines the turbidity of liquids using the light absorption and scattered light measuring method. The in-line measuring cell at the sensor set makes use of two IR transmitters and one IR receiver in pulsating light mode (*IR measuring method according ISO 7027*). The interconnected BAMOPHOX TUR measuring amplifier (*Option*) analyses the 4 to 20 mA signal generated by the sensor set.

3 MOUNTING

- The fixture must be installed vertically.
- Best installation is the mounting in an ascending tube with slow down section 600 mm in front and 400 mm behind the turbidity-measuring device.
- The sensor fixture must be completely filled with liquid during the performance of measurements.
- Install to the vertical portion of a siphon trap if necessary.
- Air bubbles distort measurement results.
- Glass windows must be clean, clean them at regular intervals as required.

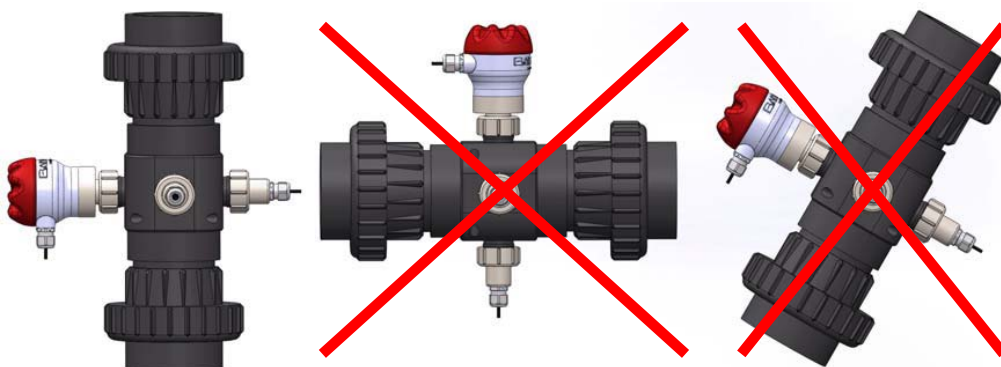
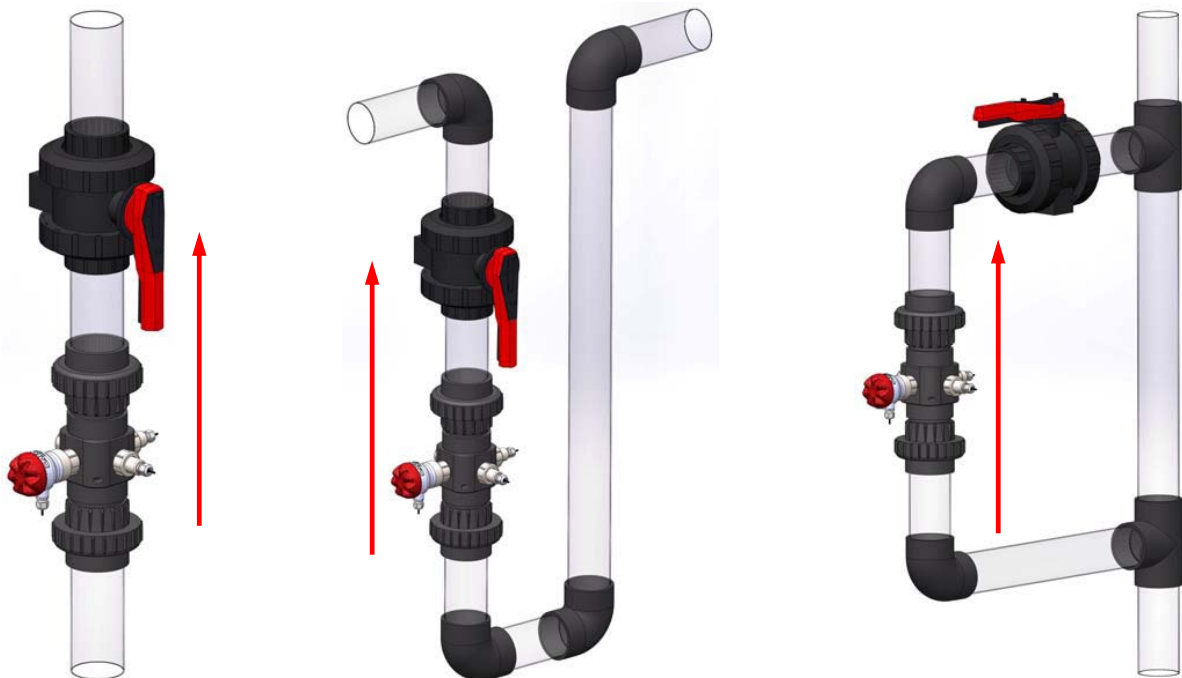

The TURBICUBE housing is equipped with 4 fixing M6 thread, which could be used for wall mounting. The supporting bracket could be drilled following drawing below:

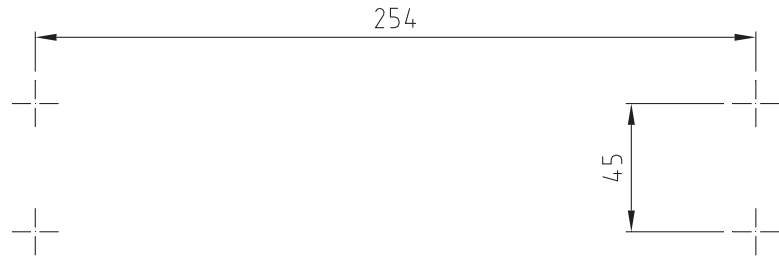
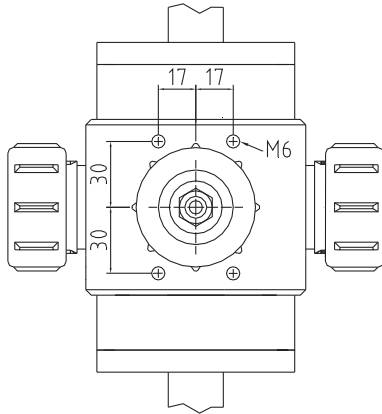

4 Set up / Displays – TURBICUBE 1000 – (Measuring range 0.1 to 1000 FNU)

The sensor set consists of a receiver module with microprocessor-controlled analysis electronics and two emitter modules. The sensor set generates a 4 to 20 mA output signal in accordance with the following diagram. Measuring ranges are selected with the help of the DIP switches on the receiver module.

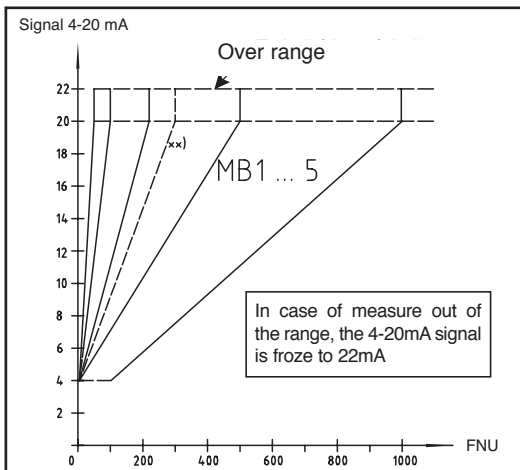

Note: The turbidity measuring instruments are calibrated with the internationally specified standard suspension Formazin.

The indication takes place thus not in form of the measured light intensity, but as concentration of the Formazin calibration suspension.

During the measurement with any liquid, this means thus that the liquid concerned causes the same light scattering as the standard suspension of the indicated concentration.

Measured values of other turbidity measuring instruments, which use other calibration suspensions and measuring angle, cannot be compared directly with those with Formazin calibrated measuring instruments.

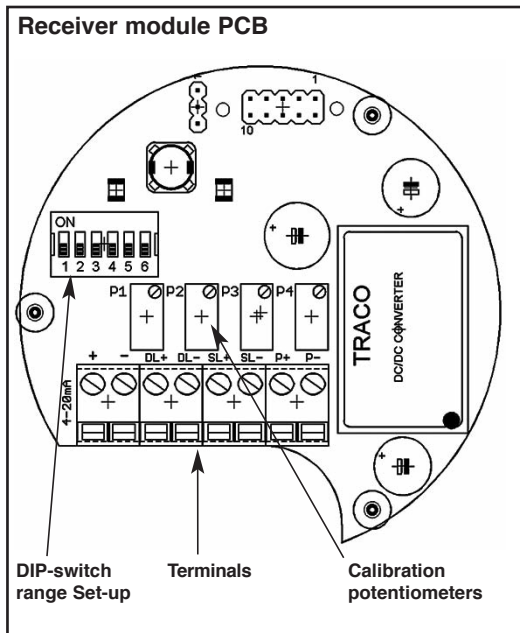

Measuring range	DIP1	DIP2	DIP3	DIP4	DIP5*	DIP6*
MB1 = 0,1... 50 FNU	OFF	OFF	OFF	ON	NC	NC
MB2 = 0,1...100 FNU	ON	OFF	OFF	ON	NC	NC
MB3 = 0,1...200 FNU	OFF	ON	OFF	ON	NC	NC
MB4 = 0,1...500 FNU (**300)	ON	ON	OFF	ON	NC	NC
MB5 = 100...1000 FNU	OFF	OFF	OFF	OFF	NC	NC

*) DIP5 and 6 without function, Normal position = OFF

**) Armatures with nominal diameter > DN 65

	Indication
Green LED = 1Hz blinking	Ready, measuring in operation
Green LED = permanent ON	Ready, measuring not in operation
Green LED = OFF	No power supply, or defective

	Fault indication
Red LED = ON	Measuring circuit faulty (short circuit, or broken)

Signal in limit conditions:

0 mA = wrong connected and / or dip-switches wrong adjusted / **4 mA** = 0 FNU (clearest water, pipe filled)
20 mA = 100% output acc. to adjusted range (*pipe filled*) / **22 mA** = over range / **21 mA** = general failure on electronics

When pipe is empty:

- If there are no water drops on the glasses the output will be a little bit higher than 4 mA (*depending on the refraction index of air-molecules*).
- If there are water drops on the glasses the output is higher than 4 mA, but the signal depends on size and quantity of water drops.

So it's important to install the turbidity measurement system always in such a way that the pipe is filled at any time (vertically or with a siphon). That's valid not only for TURBICUBE but for all systems on the market.

5 WIRING

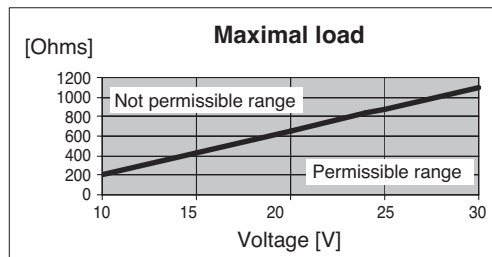
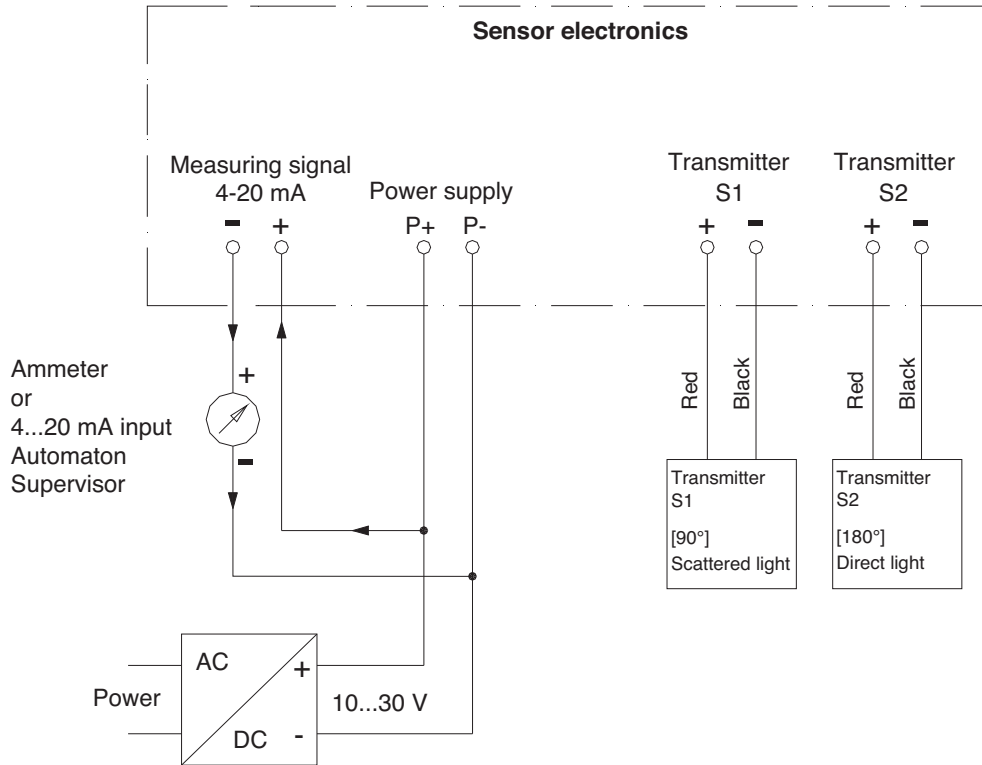

NOTE: The measuring output "4-20 mA" is a current drain, this means, the output channel has the same electrical behaviour as a variable resistor. An active power supply for the measuring circuit is always needed.

For connection to BAMOPHOX TUR, please see specific documentation msa436-01.

6 TECHNICAL FEATURES

Auxiliary power supply:	24 V DC, stabilized (10...30 V DC)
Power consumption:	0,5 W
Output signal:	4-20 mA for connection to the BAMOPHOX TUR 436
Ambient temperature:	+5...+45°C
Process temperature:	+5...+60°C (PVC), +5...+80°C (PPH)
Material:	PVC or PPH housing / Terminal housing plastic PBT, IP 65
Accuracy:	±5% reading, ±1% full scale in use
Pressure:	6 bar max. at 20°C / 1 bar max. at 60°C
Indicators:	Statut LED (<i>green</i>), "Fault" LED (<i>red</i>)
Resolution:	0.001... 0.2 FNU according to measuring range

Measuring ranges	ND 20...ND 65:	0.1...50 FNU	0.1...100 FNU	0.1...200 FNU	0.1...500 FNU	100...1000 FAU
	ND 80...ND 100:	0.1...50 FNU	0.1...100 FNU	0.1...200 FNU	0.1...300 FNU	100...1000 FAU

Process connections ND 20...ND 100: PVC or PPH unions socket ends / Flanges ISO 7005, EN 1092, DIN 2501

CE Mark: In accordance with low-voltage directive (2006/95/CE), EMC directives (2004/108/EG)

7 PROCESS CONNECTIONS & DIMENSIONS

ND	(d)	L PVC model with unions socket end	L PVC model with flanges	L PPH model with unions socket end	L PPH model with flanges
ND 20	Ø 25	240	240	300	300
ND 25	Ø 32	240	240	300	300
ND 32	Ø 40	240	240	300	300
ND 40	Ø 50	240	240	300	300
ND 50	Ø 63	262	262	342	300
ND 65	Ø 75	314	314	342	300
ND 80	Ø 90	347	347	394	400
ND 100	Ø 110	347	347	394	400

Installation: Only for vertical fully loaded pipes, with ascending flow
Slow down sections 600 mm before device and 400 mm after device

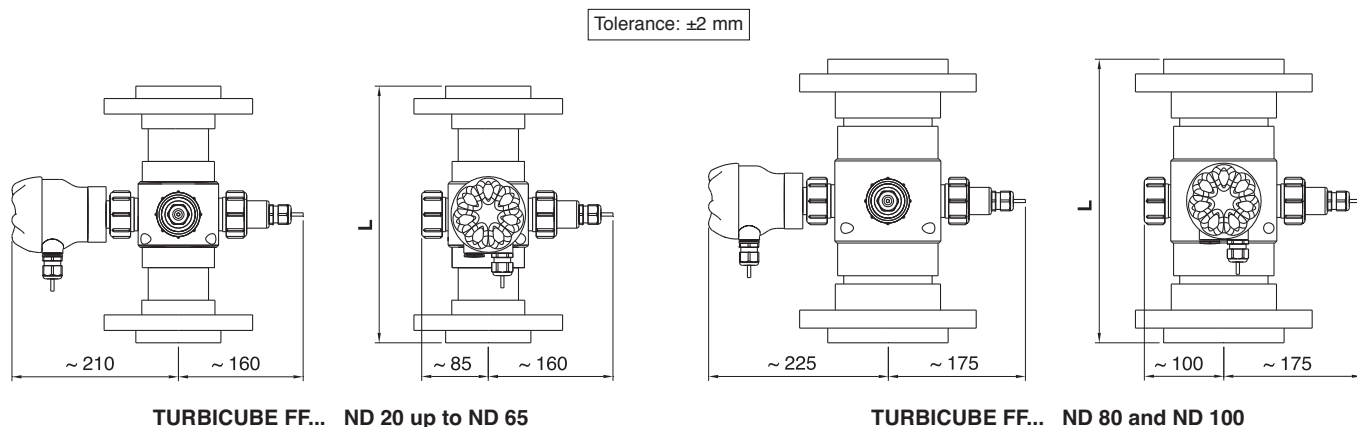
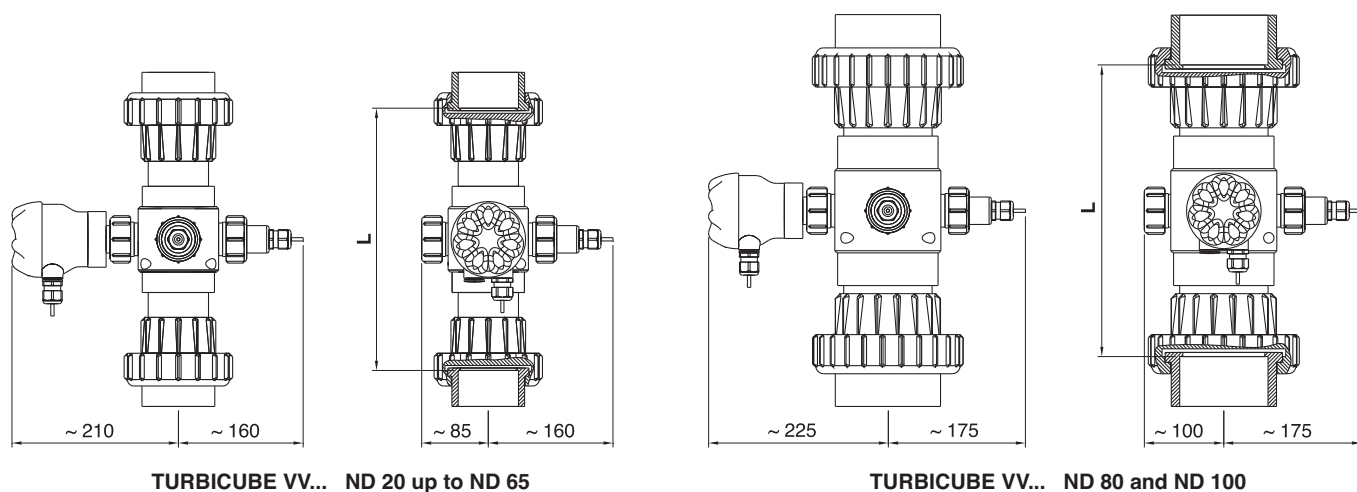

8 MAINTENANCE

Cleaning intervals depend upon the type of liquid medium and must be determined by the user.

Cleaning the lenses:

- Disconnect the turbidity-measuring instrument from all sources of power.
- Depressurize pipes and empty liquid medium from the device.
- Remove the transmitters and the receiver from the fixture by unscrewing the sleeve nuts.



1) Screw the ETR-glass with the included tool and remove.



2) Clean the lens – **Do not use abrasive cleaners, which may cause scratching.**

Note: Inspect the O-ring before assembly and replace if necessary.

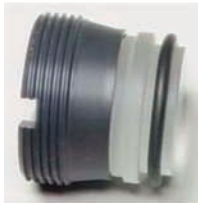

Be careful:

Lubricate the O'ring with lubricant (i.e : wask liquid) and slide it on the glass. It should be mounted on the center, approximately as shown in the picture

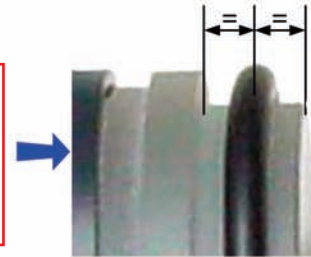

- After cleaning, remount ETR glasses, following reverse instructions.
- Tighten the glasses with the included tool.
- Before reinstalling the transmitters and the receiver, refill the fixture with liquid medium and inspect for possible leaks.



Observe positioning of hole and pin!



Note for cold fluids:

- The fixture has to be installed on the piping with mounted sensors only.
- To clean the glasses, dismantle the complete fixture. After cleaning install as described above.