

WIRING INSTRUCTION of BNC PLUG

Code 368 208

BNC/BRG type

Code 368 210

BNC/CCA type

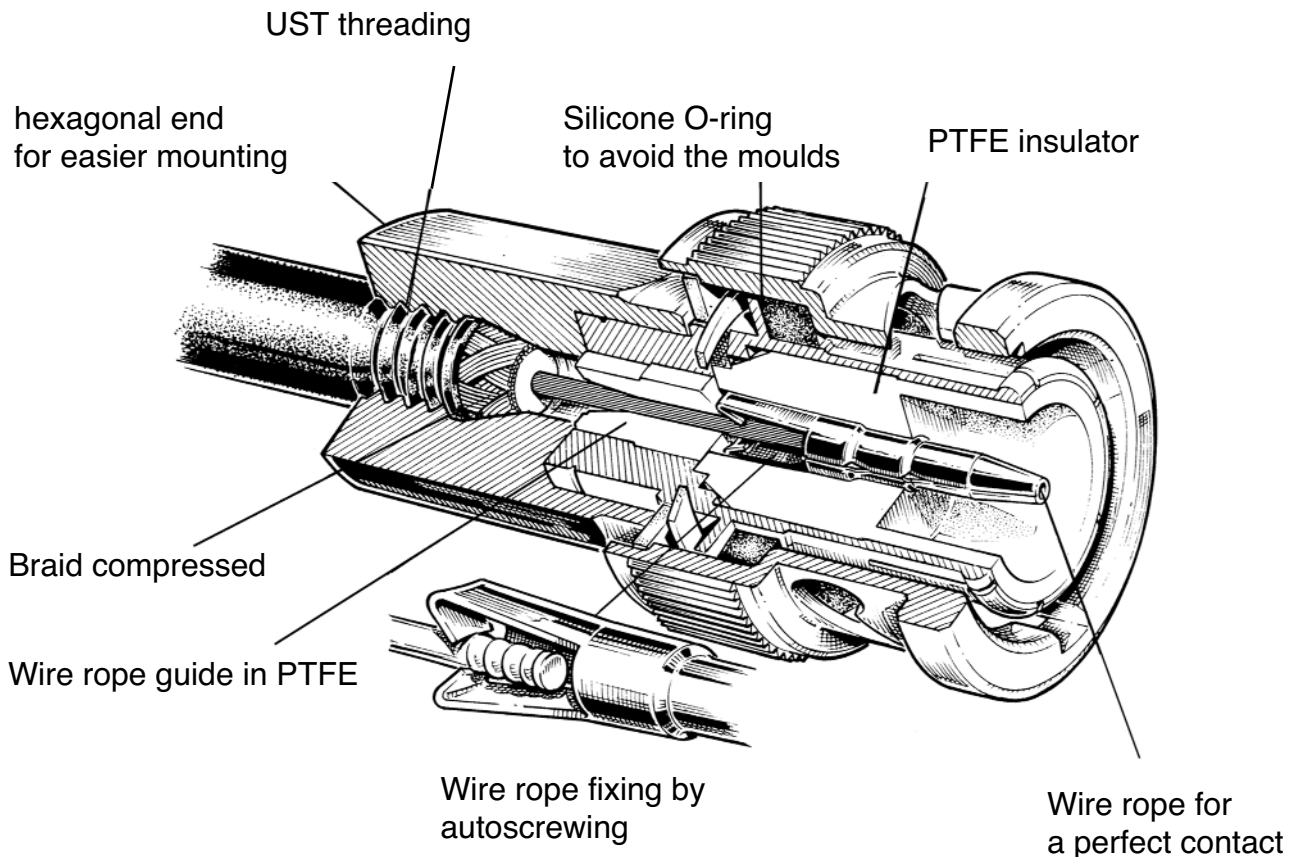

WIRING

- Strip the cable as it is shown.
- Cut the wire rope at 30° to have a good cable position in the connector.
- Twist the wire rope to make it more rigid.
- Put down the shield of one mm to bore a part of a dielectric. if this stage is wrongly done, you will get short circuit
- Introduce the cable in the connector and screw this one with the exagonal end, and push it smoothly.

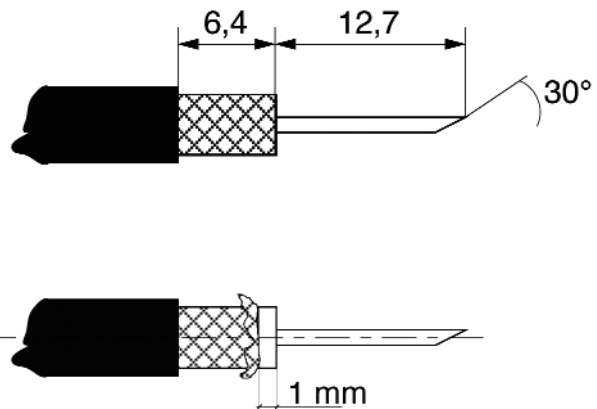

BAMO MESURES

22, Rue de la Voie des Bans - 95 100 ARGENTEUIL - FRANCE
 Tél : (+33) 01 30 25 83 20 - E-mail : info@bamo.fr
 Fax : (+33) 01 34 10 16 05 - Site : http://www.bamo.fr

BNC PLUG

MES

368-01/1

15-05-2006

368 M1 01 B