

PVC SEDIMENT STRAINER



- Eliminate solid impurities
- Possible maintenance without disassembling
- 1,5 mm standard hole pitch
- Connection by spigot ends to be stick (1/2 Union or flanges on request)
- Housing : PVC (PP & PVDF on request)
- Seals : EPDM (FPM on request)
- Strainer : PVC / Stainless steel

ARTICLES NUMBER & DIMENSIONS

Female spigot ends (Fig. A)							
TYPE	PVC/ transparency	d	DN	PN	H	t	L
FT-P65-F	955 065	75	65	6	179	44	243
FT-P80-F	955 080	90	80	4	192	51	262
FT-P100-F	955 100	110	100	4	231	61	325
Male spigot ends (Fig. B)							
TYPE	PVC/ transparency	d	DN	PN	H	t	L
FT-P10-M	P54 057	16	10	16	72	14	114
FT-P15-M	P69 908	20	15	16	72	16	124
FT-P20-M	P69 909	25	20	16	84	19	144
FT-P25-M	P67 673	32	25	16	95	22	154
FT-P32-M	P69 910	40	32	10	110	26	174
FT-P40-M	P69 911	50	40	10	120	31	194
FT-P50-M	P69 912	63	50	10	139	38	224

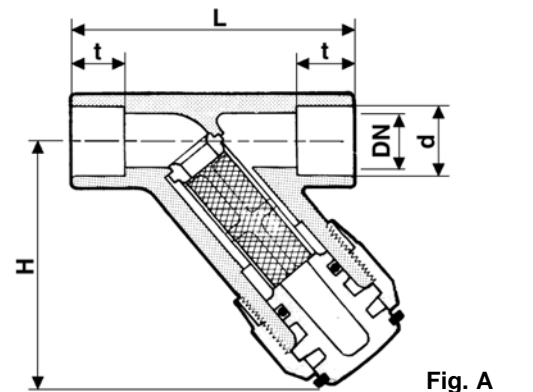

Fig. A

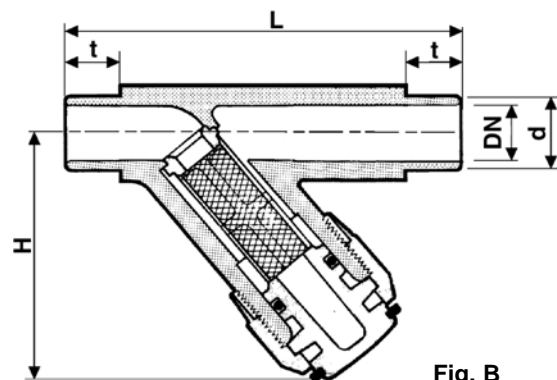

Fig. B