

In-line turbidity transmitter TRUBOMAT® GAB

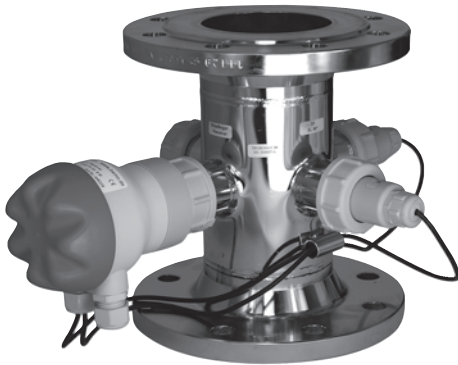

TRUBOMAT GAB 20 or 1000
Flanges connection

- Flow-through in-line turbidimeter acc. ISO 7027
- Turbidity transmitter
with two IR emitters and one IR receiver
- Two models: 0.01...20 FNU (5 ranges)
0.1...1000 FNU / FAU (5 ranges)
- 4-20mA output signal (4 wires)
- Flange or triclamp connections

PRINCIPLE

The TRUBOMAT measures the turbidity of liquids using the light absorption and scattered light measuring method.

The inline measuring cell includes two IR emitters and one IR receiver in pulsating light mode (IR measuring method according ISO 7027).

When interconnected, the BAMOPHOX TUR, measuring amplifier, analyses the 4 to 20 mA signal generated by the TRUBOMAT.

DESCRIPTION

The flow-through cell allows the turbidity measurement directly on the line, without sampling system. Its built-in transmitter is convenient for transmitting the signal to installed DCS or PLC or BAMOPHOX TUR. The 4-20 mA corresponds to the DIP Switch selectable range:

TRUBOMAT 20: from 0.01 to 20 FNU in 5 selectable ranges

TRUBOMAT 1000: from 0.1 to 1000 FNU / FAU in 5 selectable ranges

TRUBOMAT GAB-20
Range 0,01...20 FNU

or

TRUBOMAT GAB-1000
Range 0,1...1000 FNU / FAU

APPLICATIONS

- Drinkable and waste water plants, well water monitoring
- Filtration control, flocculants dosage, phase separation
- Pollution survey



TRUBOMAT GAB 20 or 1000
Triclamp connection

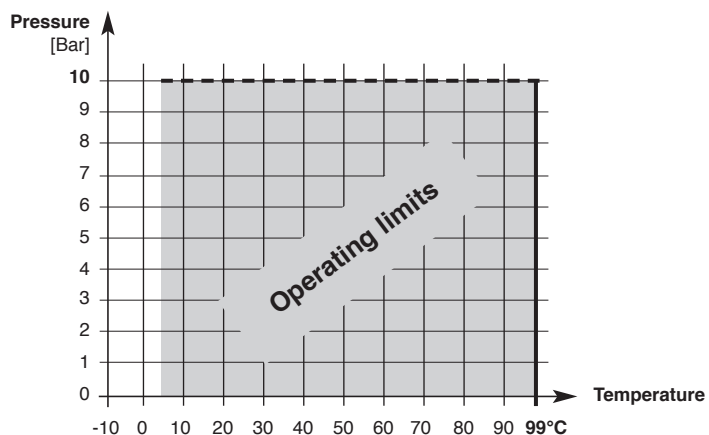

BAMO MESURES

22, Rue de la Voie des Bans - Z.I. de la Gare - 95100 ARGENTEUIL

Tél : (+33) 01 30 25 83 20 - Web : www.bamo.fr

Fax : (+33) 01 34 10 16 05 - E-mail : info@bamo.fr

In-line turbidity transmitter
TRUBOMAT® GAB

04-03-2015

446 I1 01 F

TUR

446-01/1

TECHNICAL FEATURES

Power supply:	24 V DC rated (10...30 V DC)
Power consumption:	0,5 W
Output signal:	4-20 mA, for connection to the BAMOPHOX TUR 436
Ambient temperature	+5...+45 °C
Process temperature	+5...+100 °C
Material:	316L Stainless steel body / Terminal housing plastic PBT, IP 65
Accuracy:	±5% reading, ±1% full scale in use
Resolution:	0,001...0,2 FNU according to measuring range

Measuring ranges	ND 25...ND65 :	0.1...50 FNU	0.1...100 FNU	0.1...200 FNU	0.1...500 FNU	100...1000 FAU
TRUBOMAT GAB 1000	ND 80...ND 100 :	0.1...50 FNU	0.1...100 FNU	0.1...200 FNU	0.1...300 FNU	100...1000 FAU

Measuring ranges	ND 25...ND 100 :	0.01...1 FNU	0.01...2 FNU	0.01...5 FNU	0.01...10 FNU	0.01...20 FNU
TRUBOMAT GAB 20						

Process connections:	PN10 flanges (DIN 2633), Triclamp (DIN 11850)
CE Mark:	In accordance with low-voltage directive (2006/95/EG), EMC directives (2004/108/CEE)

PROCESS CONNECTIONS & DIMENSIONS

ND	L: Flanges DIN 2633	L: Triclamp DIN 11850
ND 25	274	288
ND 32	252	266
ND 40	230	244
ND 50	190	202
ND 65	233	249
ND 80	208	218
ND 100	240	260

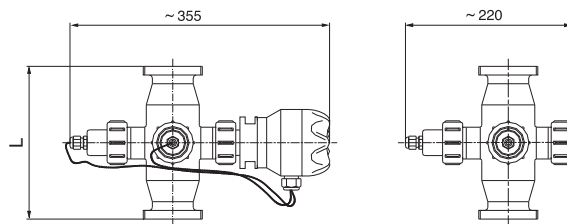

Installation: Only for vertical fully loaded pipes, with ascending flow
Slow down sections 600 mm before device and 400 mm after device

CODE NUMBERS AND REFERENCES

Code	Reference	Designation	
446 123	GAB - 1000 - FF - 3	Stainless steel fixture - Range 0.1 to 1000 FNU - Flange connections PN 10 (DIN 2633)	ND 25
446 124	GAB - 1000 - FF - 4	-	ND 32
446 125	GAB - 1000 - FF - 5	-	ND 40
446 126	GAB - 1000 - FF - 6	-	ND 50
446 127	GAB - 1000 - FF - 7	-	ND 65
446 128	GAB - 1000 - FF - 8	-	ND 80
446 129	GAB - 1000 - FF - 9	-	ND 100
446 223	GAB - 20 - FF - 3	Stainless steel fixture - Range 0.01 to 20 FNU - Flange connections PN 10 (DIN 2633)	ND 25
446 224	GAB - 20 - FF - 4	-	ND 32
446 225	GAB - 20 - FF - 5	-	ND 40
446 226	GAB - 20 - FF - 6	-	ND 50
446 227	GAB - 20 - FF - 7	-	ND 65
446 228	GAB - 20 - FF - 8	-	ND 80
446 229	GAB - 20 - FF - 9	-	ND 100
446 143	GAB - 1000 - TC - 3	Stainless steel fixture - Range 0.1 to 1000 FNU - Flange connections Triclamp (DIN 11850)	ND 25
446 144	GAB - 1000 - TC - 4	-	ND 32
446 145	GAB - 1000 - TC - 5	-	ND 40
446 146	GAB - 1000 - TC - 6	-	ND 50
446 147	GAB - 1000 - TC - 7	-	ND 65
446 148	GAB - 1000 - TC - 8	-	ND 80
446 149	GAB - 1000 - TC - 9	-	ND 100
446 243	GAB - 20 - TC - 3	Stainless steel fixture - Range 0.01 to 20 FNU - Flange connections Triclamp (DIN 11850)	ND 25
446 244	GAB - 20 - TC - 4	-	ND 32
446 245	GAB - 20 - TC - 5	-	ND 40
446 246	GAB - 20 - TC - 6	-	ND 50
446 247	GAB - 20 - TC - 7	-	ND 65
446 248	GAB - 20 - TC - 8	-	ND 80
446 249	GAB - 20 - TC - 9	-	ND 100

BAMO MESURES

22, Rue de la Voie des Bans - Z.I. de la Gare - 95100 ARGENTEUIL

Tel : (+33) 01 30 25 83 20 - Web : www.bamo.fr

Fax : (+33) 01 34 10 16 05 - E-mail : info@bamo.fr

In-line turbidity transmitter
TRUBOMAT® GAB

04-03-2015

446 I1 01 F

TUR

446-01/2